

**HJS**

***Quality assurance, Sustainability &  
Environmental Protection Agreement***

***In The Supply Chain***



***This agreement is the contractual definition of the technical and organizational conditions and processes between HJS Emission Technology GmbH & Co. KG and the supplier.***

The company HJS commits itself and its suppliers to achieve the target to deliver products and services

- ✓ Without Failure
- ✓ At the right time
- ✓ In the right amount
- ✓ Sustainable
- ✓ Environmentally aware

.... and to continuously improve in this every day...

***Because you want to do business  
with us and we want to do  
business with our customers also  
for the next generations...***

**The HJS purchase process basically consists of 4 elements:**

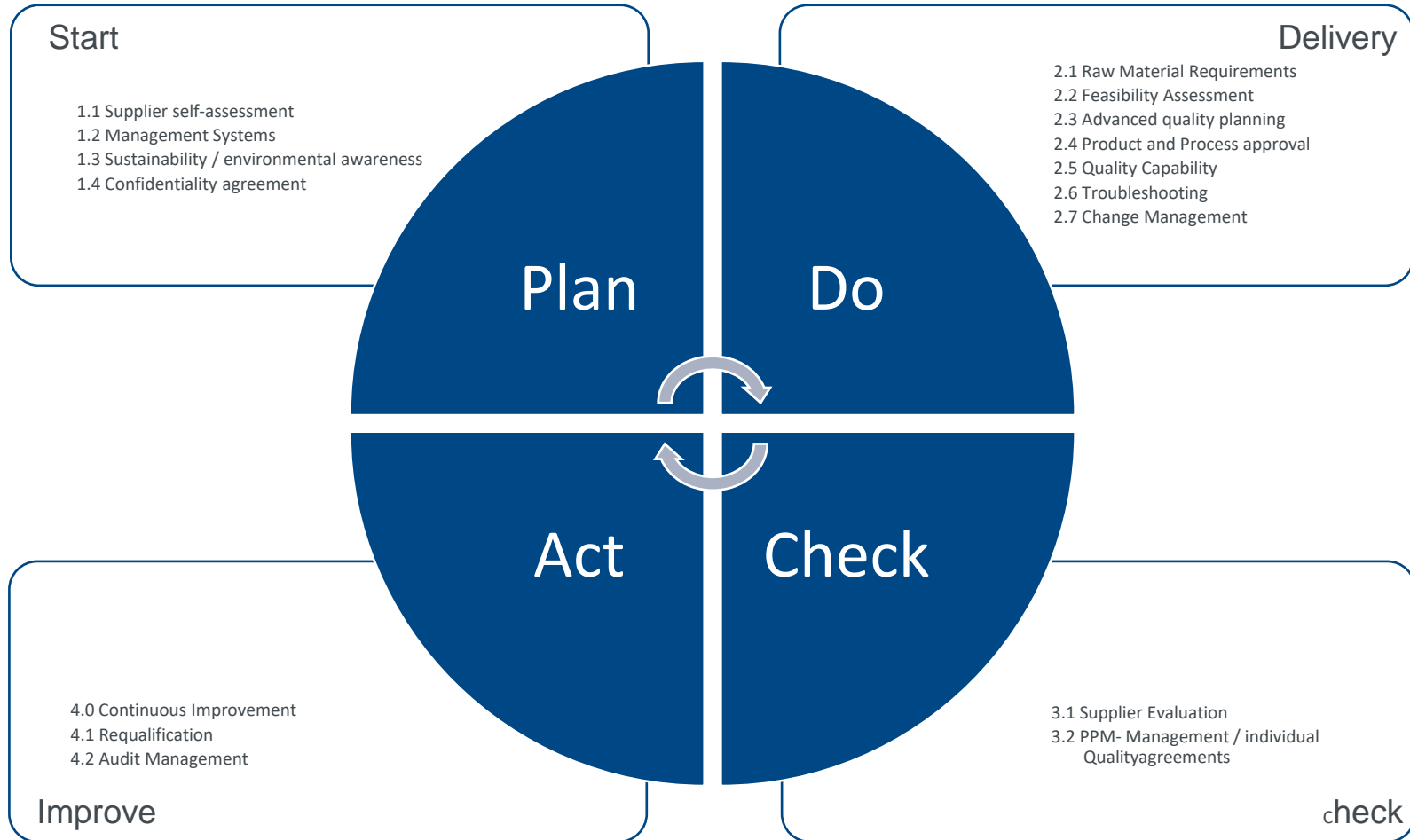

## 1.1 Supplier self-assessment

In order to ensure that the supply relationship starts as smoothly as possible, it is important to have all the information clearly available.

For this purpose we will provide you with the following documents:

- HJS general terms and conditions of purchase
- C5-FB-04 - Supplier self-assessment
- C5-TS-02 - Quality, sustainability and environmental guidelines
- C4-TS-04 - Packaging regulations HJS
- HJS Confidentiality Agreement

These are fundamental for a supply relationship and must be checked/completed and confirmed

All information provided in the supplier-self-assessment is binding. They will be evaluated by a team from the environment, quality and purchasing departments at HJS and finally signed by both parties (HJS/Supplier).

Any change in the information must be reported to HJS immediately after it becomes known.

The supplier self-assessment signed by both parties is the basic approval for establishing a supply relationship.

HJS		Lieferantenselbstauskunft / Supplier Self-Audit			HJS Formblatt C5-FB-04 Ausgabe: 15-12-2021	
<b>Firmendaten / Company Data</b>						
Firmenname Company Name						
Straße Street						
Postleitzahl und Ort Post code and Location / C		Land Country				
Telefonnummer Phone-No.		Faxnummer Fax-No		e-Mail		
Internet (URL)						
	Name	Phone	Fax	e-Mail		
Geschäftsleitung Managing Director						
Technische Leitung Technical Manager						
Produktionsleiter Production Manager						
Vertriebsleiter Sales Manager						
QM-Leitung QM-Manager						
Beauftragter für Produkticherheit & Konformität Product Safety & Conformity						
UM-Leitung/beauftragter UM-Manager						
Bitte geben Sie die Fertigungsverfahren Ihrer zu liefernden Produkte oder zu liefernden Dienstleistungen an. Please name the production processes of your products or supplied service.						
Entwicklungsschwerpunkte Main developments						
Rechtsform Legal form		Eigentumsverhältnisse Owner and Owners interest				
Konzernzugehörigkeit Part of a conglomerate / group		Eigenkapitalquote Equity ratio				
Investitionen der letzten 3 Jahre Capital expenditure last 3 years		Fremdkapitalquote Foreign capital ratio				
Anzahl der Mitarbeiter Number of employees		Vorjahres-Umsatz Last year's turnover [Euro]				
• in der Produktion • within production		Gesamtumsatz der letzten 3 Jahre Total -Turnover of the previous 3 years				
• im Qualitätsbereich • within Quality Department		Anteil HJS am Umsatz [%] share of HJS [%]				
Vertragen Sie über eine Betriebsvereinbarung						

## 1.2 Managementsystem

The supplier commits to develop, introduce and maintain at least one quality management system in accordance with ISO 9001 towards HJS.

Cause our products are used in different industries with different purposes, additional management systems are necessary depending on the industry and area of application of the products.

Evidence of the respective management systems must be attached to the supplier self-assessment C3-FB-04 as part of the supplier evaluation process. When a certificate expires, the currently valid certificate must be sent to HJS without request.

Any change in the management system that affects the certification must be reported to HJS immediately after it becomes known.

- This means e.g. when changing:
- company name
- name/address of a production site,
- Loss of certificate / levy
- Scope
- Relocations
- Etc...

The supplier ensures that its sub-suppliers also meet the above requirements. As proof, the supplier is able to present the valid certificate of an accredited certification company (as shown).



Each certificate must contain the seal of a recognized member of the International Accreditation Forum Multilateral Recognition Arrangement!

## 1.3 Compliance with legal requirements / other guidelines

When delivering the goods and providing services, the supplier must observe all applicable regulations, in particular with regard to occupational health and safety, working conditions and environmental protection, as well as all applicable laws and regulations of the country concerned and ensure that all of its employees and subcontractors or agents comply with these rules, laws and regulations.

- In order to preserve our environment for future generations, we recommend the introduction and implementation of environmental management according to ISO 14001 and/or EMAS or ISO 50001
- We recommend carrying out life cycle assessments based on ISO 14040 ff to determine and improve the overall environmental profile
- The supplier assures for his company that the products to be delivered are manufactured or processed without exploitative child labor within the meaning of ILO Convention No. 182 and that this is also required of his suppliers.

[https://www.ilo.org/wcmsp5/groups/public/---ed\\_norm/---normes/documents/normativeinstrument/wcms\\_c182\\_de.htm](https://www.ilo.org/wcmsp5/groups/public/---ed_norm/---normes/documents/normativeinstrument/wcms_c182_de.htm)

- The supplier will not employ anyone against their will. Employees have the right to terminate their employment within a reasonable period of time. The requirements of the ILO Convention No. 29 must be observed and passed on to his suppliers.

[https://www.ilo.org/wcmsp5/groups/public/---ed\\_norm/---normes/documents/normativeinstrument/wcms\\_319064.pdf](https://www.ilo.org/wcmsp5/groups/public/---ed_norm/---normes/documents/normativeinstrument/wcms_319064.pdf)

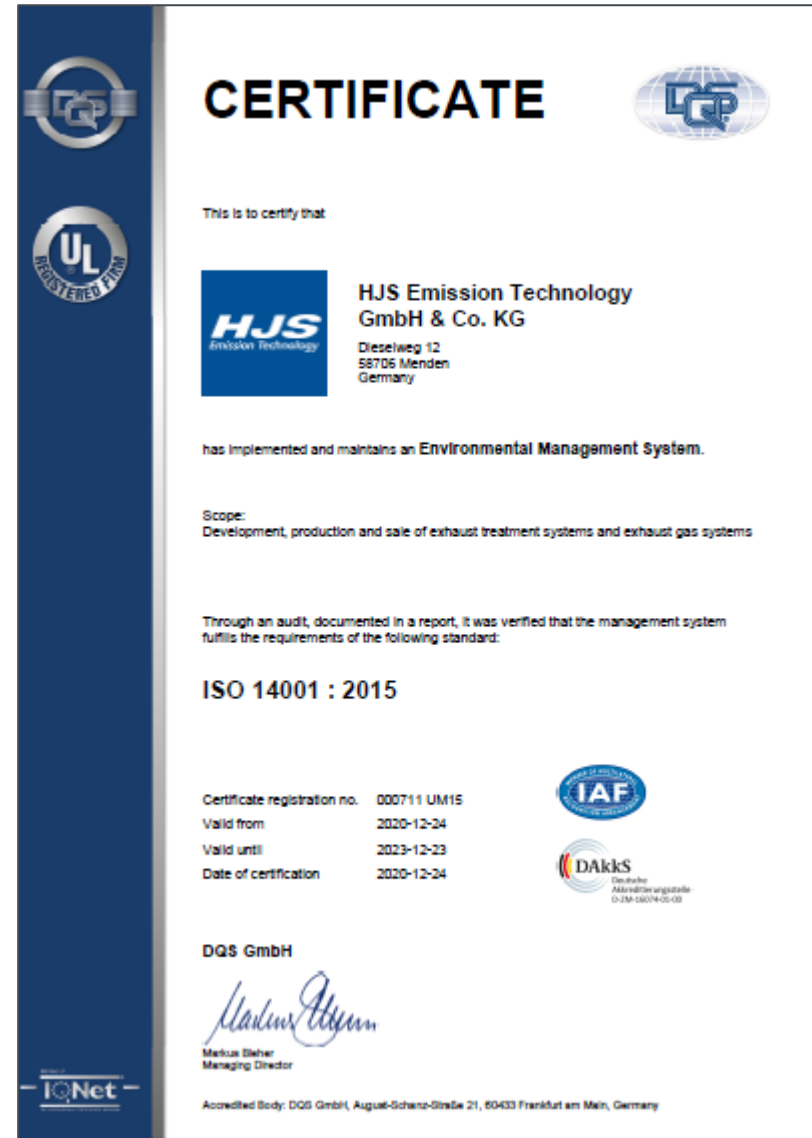

**CERTIFICATE**

This is to certify that

**HJS Emission Technology GmbH & Co. KG**  
Dieselweg 12  
58706 Menden  
Germany

has implemented and maintains an **Environmental Management System**.

Scope:  
Development, production and sale of exhaust treatment systems and exhaust gas systems

Through an audit, documented in a report, it was verified that the management system fulfills the requirements of the following standard:

**ISO 14001 : 2015**

Certificate registration no. 000711 UM15  
Valid from 2020-12-24  
Valid until 2023-12-23  
Date of certification 2020-12-24

**DQS GmbH**  
Markus Dieber  
Managing Director

Accredited Body: DQS GmbH, August-Schanz-Straße 21, 60433 Frankfurt am Main, Germany

Logos: IAF, DAKKS, UL REGISTERED FIRM, IQNet

## 1.4 Principles of fair competition / Anti-corruption

HJS rejects corruption and bribery. In dealings with business partners and government institutions, the interests of the company and the private interests of employees on both sides are strictly separated. Decisions are made free of extraneous considerations and personal interests. The applicable law on corruption must be observed.

Among other things, the following must be observed:

The granting of personal benefits by HJS and its employees to national or foreign public officials (such as civil servants or employees in public service) with the aim of obtaining advantages for the company or themselves or third parties is not permitted.

Monetary personal benefits in return for unfair preferability in business dealings may not be offered, promised, granted or approved. Likewise, personal advantages in return for unfair preferability in business dealings may neither be demanded nor accepted in dealings with business partners. Management and employees may not offer, promise, demand, grant or accept gifts, payments, invitations or services in business dealings that are granted with the intention of unfairly influencing a business relationship or where there is a risk of jeopardizing the professional independence of the business partner. This is generally not the case with gifts and invitations that are within the scope of customary business hospitality, custom and courtesy.

# Sustainability And Environmental Protection



## 2.1 Raw Material Requirements

If a delivery contains chemical substances, mixtures and/or products that are subject to the following European legal regulations:

RoHs 2011/65/EU  
Reach 1907/2006  
Conflict Minerals 2017/821

The supplier must comply to this regulations with all obligations resulting from the corresponding and any supplements. The supplier also commits to impose these obligations on any subcontractors. If the marketing of a delivery item is restricted and/or discontinued due to one of the above-mentioned regulations, the supplier shall inform the customer of this in writing at least six weeks before the impediment, restriction and/or discontinuation takes effect. The supplier is liable for any breach of the above obligations.

If a supplier does not come from the european unit, a corresponding letter of explanation must be prepared. This letter and further information can be found at our homepage in the download area

<https://www.hjs.com/unternehmen/einkauf/>

If required in the order, a corresponding entry must be made in the IMDS system:

<https://www.mdssystem.com>



Think about tomorrow.



**Supplier confirmation declaration**  
- EU Regulation 1907/2006/EC Annex XVII Compliance Non EU supplier -

Company Name	
Street	
Postal code and City	
Country	

1. We commit ourselves to communicate to HJS Emission Technology GmbH & Co. KG if one of the articles supplied by us contains substances for which Annex XVII defines a restriction.
2. We guarantee that no substances for which Annex XVII contains a restriction will be used in one of your products unless it complies with the conditions of that restriction.
3. We guarantee that all delivered products comply with the substance restrictions regulated in the current version of Annex XVII REACH.
4. The requirements mentioned in the "Annex XVII Compliance Non EU supplier" are legally binding and part of our standard business terms.

\_\_\_\_\_      \_\_\_\_\_      \_\_\_\_\_  
date                      address                      contact person  
responsible for REACH issues



## 2.2 Feasibility assessment of product/service specifications.

In addition to the standards listed, the HJS order documents are binding,

e.g.:

- Drawings
- DIN standards / HJS standards,
- Technical terms of delivery, data sheets, etc.
- Agreed test instructions and test equipment
- Additional order information, e.g. B. Packing instructions
- Special legal regulations
- Special regulations for environmental protection and recycling

If anything is unclear / or missing information, these have to be requested...

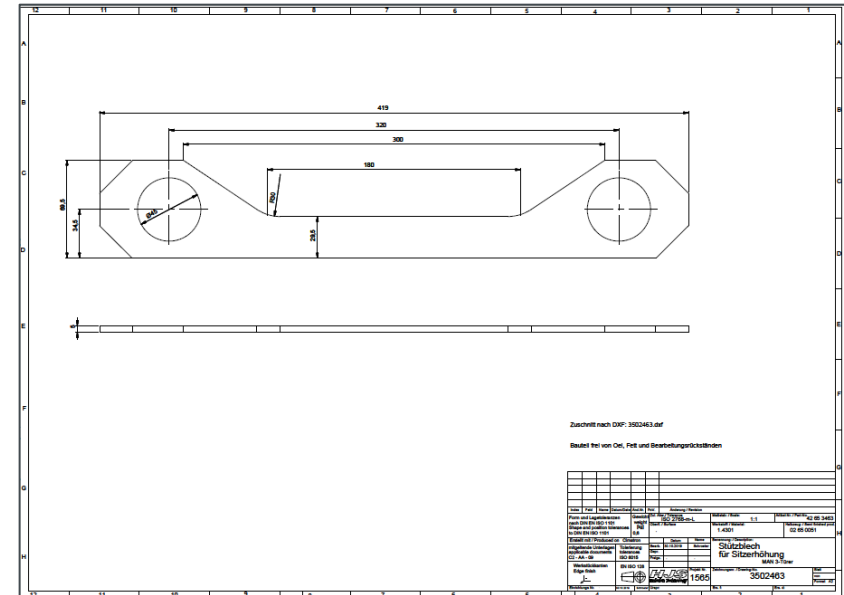

**All specifications provided must be subjected to a feasibility assessment before the offer is made.**

**By sending an offer to HJS, the supplier confirms that the product can be manufactured / the service can be provided for the stated cost.**

## 2.3 Methods / documentation of quality planning

To ensure the goal of "zero-defect quality" in all phases of the product life cycle, it is important to plan, control and document them appropriately.

The following methods/documentation are to be used for this in order to achieve/ensure consistent quality.

- Process flow diagram (definition of quality-related processes)
- Product/ process risk analyzes (definition of the appropriate scope of testing e.g. FMEA)
- Control plan (definition of the scope of testing)
- Inspection plan (specification/documentation of the results of the scope of inspection in production)
- Initial sampling (validation of the scope of testing + approval by HJS)
- Basic for the methods described in VDA Volume 4 should be used as guideline for this

### Product- and Process-FMEA

Considering the use of its products at HJS and its customers, the supplier carries out preventive risk analyzes (e.g. FMEA) for all products delivered to HJS and the associated processes and updates these in the event of any deviations in product and/or process quality and changes corresponding.

Points assessed as critical have to be improved immediately by means of suitable corrections and preventive measures so that specification, properties and product safety as well as capable production can be guaranteed.

**The scope of a risk assessment should always be appropriate. We recommend part families, standardization and digitization for these topics.**

**If you have any further questions about this, simply get in touch with our supplier management team. We can support or advice for the next steps with you.**

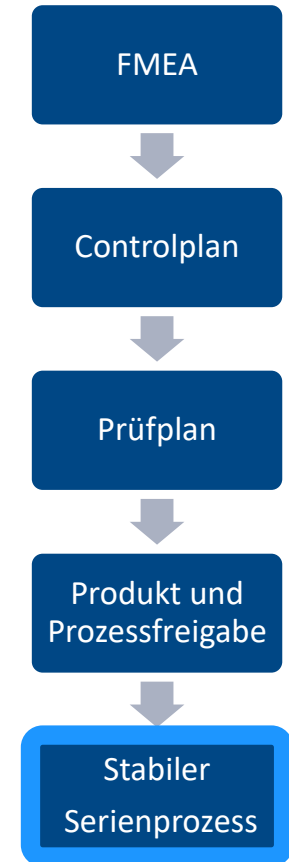

# Quality Planning For Software:



When developing and delivering automotive-specific, product-related software or products with integrated software, the supplier must implement and maintain a quality assurance process.

- In order to evaluate the software development process, the supplier must use software development evaluation methods.
- The assessment must include a prioritization of risks and potential impacts for HJS and the end customer.
- The results of software development skills self-assessments must be documented and retained

**The guideline VDA volume 1 is to be used to determine the retention period of the documentation.**

## 2.4 Product and process release

For product release, the supplier must present initial samples to HJS before the start of series delivery, which correspond to all contractually agreed specifications and properties with regard to:

- Measurements / dimensions
- Material / Substances
- Function

The initial samples and all individual parts and materials used in their production must be manufactured entirely using series equipment and under series conditions.

The PPF process can correspond to both the current VDA Volume 2 and the current AIAG – PPAP process.

The type and scope of the required documentation can be found in the respective order.

HJS reserves the right to charge the supplier for the costs incurred in the event of repeated rejection of initial sample test reports.



**Deckblatt zum PPF-Bericht**  
HJS Emission Technology GmbH & Co. KG

HJS Formblatt  
S3-FB-107  
Ausgabe: 20.12.2021

Organisation		Grund der Berichterstellung			
		Bericht Produktionsprozess- und Produktfreigabe (PPF)			
		Bericht sonstige Muster			
		Requalifikation			
		Auslöser PPF-Verfahren			
		Musteranstellung			
Kunde (Empfänger)		Neuteil			
		Änderungen am Produkt			
		Änderungen am Produktionsprozess			
		Änderung in der Lieferkette			
		Wiedernutzung > 12 Monate Stillstand			
		Aktualisierte PPF-Dokumentation			
Angaben zur Organisation		Angaben zu Mustern		Angaben zum Kunden	
Bereichsnummer	.....	Lieferschichtnummer	.....	Kunde	.....
Bereichsversion	.....	Liefemenge	.....	Bestellnr. PPF-Muster	.....
Liefestandort	.....	Chargennummer	.....	Abstellstelle	.....
Produktionsstandort	.....	Mustergewicht (kg)	.....	Sachnummer	.....
Sachnummer	.....	Hardwvrestand	.....	Benennung	.....
Benennung	.....	Diagnosestand	.....	Version/ Datum	.....
Zeichnungsnummer	.....	Softwvrestand	.....	Version/ Datum	.....
Version/ Datum	.....	Kennung/DUNS	.....	Version/ Datum	.....
		Hardwvfreigabe	.....	Softwvfreigabe	.....
<b>Bestätigung Organisation</b>					
Hiermit wird bestätigt, dass das PPF-Verfahren entsprechend den Vereinbarungen der Abstimmung zum PPF-Verfahren und nach den Vorgaben gemäß VDA Band 2 durchgeführt wurde.					
Der IMDS Datensatz wurde erstellt unter der MDB-ID-Nr.:					
Name	.....	Bemerkung		Unterschrift	
Abteilung	.....				
Telefon	.....				
E-Mail/Fax-Nr.	.....				
Datum	.....				
Entscheidung Kunde					
<b>Kundentauglich/Serientauglich</b>			<b>Nicht kundentauglich/ Nicht serientauglich</b>		
PPF-Verfahren zum Kunden abgeschlossen			Neues PPF-Verfahren erforderlich		
Aktualisierung der PPF-Dokumentation erforderlich					
Berichtsnummer/-version Kunde					
Name	.....	Bemerkung		Unterschrift	
Abteilung	.....				
Telefon	.....				
E-Mail/Fax-Nr.	.....				
Datum	.....				

## Quality Capability

The supplier ensures that the machines, tools, measuring and testing equipment used, as well as the processes in which they are used, are suitable for the manufacture of the products delivered to HJS, that all tolerances and properties are observed.

The supplier is fully responsible for the delivered quality, cause of this HJS limits the incoming goods inspection to externally visible transport and packaging damage as well as quantity and identity checks based on the delivery documents.

The characteristics for which proof of capability has to be provided have to be agreed between HJS and the supplier / marked on the drawing. Type and scope are described in the following Work instructions:

C2-AA-09 Description of the kinds of characteristics.

C2-AA-72 Special characteristics in the development process

These are available on our website

<https://www.hjs.com/unternehmen/einkauf/>

## Traceability

The supplier must ensure the traceability of the products.

By labeling the products or alternatively taking other suitable measures, the supplier ensures that if a defect is detected, other potentially defective products can be identified immediately, at least one production batch of the parts can be blocked until follow-up measures have been agreed between the supplier and HJS.



**The guideline VDA volume 1 is to be used to determine the retention period of the documentation.**

## Special Characteristics

Special characteristics are characteristics that require increased carefulness and are not regulated by other processes. Special characteristics are divided into three categories and identified as follows:

**BM S:** The feature has an influence on the safety / safety-relevant consequences of the vehicle / machine.

**BM Z:** Approval relevant legal and official requirements at the time of placing on the market

**BM F:** The feature has a direct influence on the function of the vehicle / machine.

Increased care is understood to mean, for example:

- Design and assurance of the function or feature using appropriate design solutions (robust design).
- Identification of special features on all relevant documents e.g.:
  - Drawings
  - FMEA
  - Control plan
  - Inspection plan

Design and execution of manufacturing processes using appropriate process solutions

- Robust devices and processes
- Poka Yoke solutions
- Compliance with process capability indicators / cpk- analyses
- Other defect-detecting tests customized to the characteristic....

Marked on drawings is as follows:

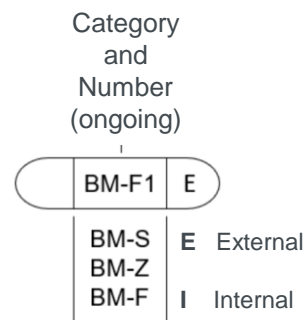

# 2.6 Problem Solving



## 2.6 Complaints processing, 8D report

- For each complaint, we require a written notification of attention of the complaint within 2 days after receipt of the complaint report by email.
- The supplier must carefully investigate the rootcause for the products complained about (fault/cause analysis). He must immediately summarize the results and planned corrective measures, including the schedule for their implementation. Evidence of the effective implementation of the corrective measures must be provided to HJS.
- If a 8D report is requested, the supplier must respond with a meaningful report within 10 working days. If this is not possible, this must be coordinated with the person responsible in the quality management at HJS. Interim reports must be provided upon request. A comparable document from the supplier with the same content is also possible.
- You can download a template for the 8D - Report here:

<https://www.hjs.com/lieferanteninformationen/>

HJS		Supplier Complaint Report / 8D-Report		HJS Form S3-FB-02 Edition: 10-08-2022	
Supplier: Name: _____ Phone: _____ Fax: _____ e-mail: _____		HJS Contact Person Name: _____ Phone: _____ Fax: _____ e-mail: _____		HJS Complaint-No.: _____ Date of issue: _____	
<b>1. Data for the process</b>					
Delivery note: _____		Part no. HJS: _____		Incorrect parts: _____	
Date of delivery: _____		Drawing / Index: _____		Decision: _____	
Delivered quantity: _____		Part name HJS: _____			
Problem description HJS: _____				Specification: _____	
Short result: Complaint accepted <input type="checkbox"/> Analysis still open <input type="checkbox"/> Complaint refused <input type="checkbox"/>					
1a Team		2a Problem description supplier			
1b Head of team		2b Repetitive Defect? Yes <input type="checkbox"/> No <input type="checkbox"/>			
3a Containment action (s)		3b % Effect	3c Implementation date	3d Responsible	
Stock affected Yes: <input type="checkbox"/> No: <input type="checkbox"/>		Work in process affected Yes: <input type="checkbox"/> No: <input type="checkbox"/>		Delivered parts affected Yes: <input type="checkbox"/> No: <input type="checkbox"/>	
4a Root cause (s) analysis („ask 5 times why“)		4b % Involvement	4c Causative departm.		
5a Planned permanent corrective action (s)		5b Responsible	5c Target date		
6a Implemented permanent corrective action (s)		6b Verification	6c Implementation date		
7a Structural actions to prevent recurrence (s) Modification of: <input type="checkbox"/> Product-FMEA <input type="checkbox"/> Process-FMEA <input type="checkbox"/> Control Plan <input type="checkbox"/> Working- / Test Instruction: _____		7b Responsible	7c Implementation date		
Are other products / processes affected? Yes: <input type="checkbox"/> No: <input type="checkbox"/>		If yes, which? _____			
Further actions?		_____			
8a Closure		8b Close date	8c Reported by		
Date: S3-FB-02_2022-08-10_Supplier_Complaint_Report_8D-Report					
MSC Public		Send report		Page 1 of 1	

## Supplier escalation procedure

If quality or logistics problems occur repeatedly at suppliers, they are included in the HJS escalation procedure. The aim of the procedure is to implement suitable measures at the supplier so that the products and materials supplied again meet the requirements of HJS. Depending on the duration and severity of the problems, they are classified into one of three escalation levels.

Basically, each stage proceeds as follows:

- **Analysis** of the cause of the escalation and the problem.
- **Agreement** on an action plan to eliminate the causes of the escalation
- **Implementation** of the action plan.
- **Monitoring**/following up of the action plan.

**Escalation level 1:** Will be used for issues due to quality problems, target deviations, repeated complaints and delays in delivery. In the complaints process, the supplier should initiate an effective solution to the problem and document this in an 8D report.

**Escalation level 2:** In escalation level 2, the corrective measures are checked on site at the supplier for adequacy and effectiveness. This can be done, as part of quality and/or logistics audits. The results of the on-site analysis are documented in an action plan. The supplier is responsible for the implementation of the measures and must regularly report the relevant status to the responsible departments.

**Escalation level 3:** If the quality requirements in escalation level 2 are not met, the supplier is classified in escalation level 3. This means that the supplier is blocked for new inquiries and awards. At escalation level 3, it can also be decided to have the existing problems analyzed by an HJS team on site. The supplier must be willing to support all activities of the HJS employees. The supplier's management must ensure compliance with the agreed measures. This is monitored and documented through regular reviews. Escalation level 3 ends when the necessary evidence for the implementation of the agreed measures has been provided. If this is not successful, the supplier concerned will be repositioned in the portfolio of HJS purchasing as a non-approved supplier.



# 2.6 Problem Solving



## Request for special release

- If there are quality defects in a product, we would like to solve these problems with you...
- This must be announced before delivery by informing HJS with the request for special release S3-FB-08.
- If this is released, it must be attached to each storage unit so that it is clearly visible upon delivery.
- The request for special release S3-FB-08 can be found here:

<https://www.hjs.com/unternehmen/einkauf/>

***We can only support you if we know about deviations in advance....***

<b>HJS</b> Emission Technology		<b>Antrag auf Sonderfreigabe / Bauabweichung</b> REQUEST FOR SPECIAL RELEASE		HJS Formblatt S3-FB-08 Ausgabe: 17-06-2020
<b>Empfänger / RECIPIENT:</b>				
Name Kunde / NAME CUSTOMER: .....				
Abteilung / DEPARTMENT: .....				
Tel. Nr. / PHONE: .....				
Fax: .....				
E-Mail: .....				
<b>Absender / SENDER:</b>				
Lieferant / SUPPLIER: .....			Tel. Nr. / PHONE: .....	
Lieferanten-Nr. / SUPPLIER CODE: .....			Fax: .....	
Kontakt Person / CONTACT PERSON: .....			E-Mail: .....	
Abteilung / DEPARTMENT: .....			Datum / DATE: .....	
<b>Hiermit beantragen wir für folgenden Artikel eine Sonderfreigabe / Bauabweichung :</b> WE ASK FOR A SPECIAL RELEASE / DEVIATION PERMIT FOR THE FOLLOWING COMPONENTS:				
Artikel/Benennung / ARTICLE DESCRIPTION: .....				
Artikel-Nr. Lieferant / ARTICLE NO. SUPPLIER: .....				
Artikel-Nr. Kunde / ARTICLE NO. CUSTOMER: .....				
Zeichnungs-Nr./Index / DRAWING NO.: .....				
Bestell-Nr. / ORDER NO.: .....				
Menge abweichender Artikel / QUANTITY OF PARTS WITH DEVIATIONS: .....				
<b>Fehlermerkmal / DEFECT, NONCONFORMITY:</b>				
Soll / NOMINAL VALUE: .....			Ist / ACTUAL VALUE: .....	
<b>Eingeleitete Sofortmaßnahme / IMMEDIATE ACTIONS:</b>				
Lieferdatum der fehlerhaften Teile (nach Freigabe): NON-CONFORMING PARTS WILL BE DELIVERED ON (AFTER RELEASE):		Menge: QUANTITY	Teile sind gekennzeichnet mit: PARTS ARE MARKED WITH:	
Datum/Unterschrift / DATE/SIGNATURE: .....				
<b>Kunde / CUSTOMER</b>				
<input type="checkbox"/> Entwicklung DEVELOPMENT		<input type="checkbox"/> Konstruktion DESIGN		<input type="checkbox"/> Qualität QUALITY DEPARTMENT
Anmerkung / COMMENT:				Freigabe erteilt: ACCEPTANCE: <input type="checkbox"/> JA / YES <input type="checkbox"/> NEIN / NO
				Name / NAME: Datum/Unterschrift / DATE/SIGNATURE:
Antwort an Lieferant erledigt durch/am / REPLY TO SUPPLIER BY/ON:				

# 2.7 Change Management



## Changemanagement

The supplier will notify HJS of any technical changes intended by the supplier for the delivery of released contractual items as early as possible, but no later than 6 months before the introduction of the change.

The required documentation, e.g. scope of EMPB, must be coordinated with HJS at an early stage.

The supplier informs HJS before implementing all planned changes to products and processes, both before and after SOP (Start of Production) e.g.:

- Design, specification or material changes
- Use of new, modified or replacement tools,
- Changed manufacturing methods or production processes,
- Production relocation within a production site or to other sites,
- Changes made by suppliers to products, parts, materials, services or software,
- Restart of production facilities after a shutdown of more than 12 months.

The obligation to provide information also applies if one of the points applies to a subcontractor.

A clear date for the first delivery of the changed status is to be announced. The delivery must be clearly marked on each storage unit.

If this procedure is not followed, HJS reserves the right to charge the supplier for the costs incurred for HJS.

## 3.1 HJS supplier evaluation process

HJS informs its suppliers at least once a year about the status of the supply relationship!

The assessment includes the factors:

- ✓ QM- System
- ✓ Product Quality
- ✓ Delivery reliability
- ✓ Quantity reliability
- ✓ Order processing
- ✓ Technical advice / support
- ✓ Pricing
- ✓ Contracts / Terms of Delivery

The result is transmitted in this detailed form

The overall result is presented as a risk classification as follows:

- A- Supplier: The delivery performance meets the requirements. Please consider this rating as a thank you for the good cooperation!
- B- Supplier: The delivery performance is not sufficient. Measures must be taken to counteract the involved factors. These have to be agreed with the responsible specialist buyer and the supplier management of HJS.
- C- Supplier: The C classification can result in a blocking for subsequent projects as well as a complete cut of the delivery relationship!

HJS		Lieferantenbewertung		HJS Formblatt C5-FB-01 Ausgabe: 23-04-2021	
Lieferantennummer	<input type="text"/>				
Lieferant	<input type="text"/>				
Beurteilt am / durch:	<input type="text" value="Mrz 21"/>				
Beurteilungszeitraum:	<input type="text" value="Jan. 21"/>	bis	<input type="text" value="Dez 21"/>		
<b>Bewertungskriterien:</b>	<b>Erreichte Punktzahl</b>	<b>Multiplikator</b>	<b>Erreichte Punktzahl</b>		
1.) Qualität	0 ... 100		max 3.500		
1.1) QM-System*		7			
1.2) Lieferqualität		28			
<small>*Grundlage: IATF 16949/VDI 6.1, ISO 9001, DIN ISO 9001, EN 29001, VDA 6.4</small>			Erreichte Punktzahl		
			<input type="text" value="0"/>		
2.) Service	0 ... 100		max 2.800		
2.1) Termintreue		14			
2.2) Mengentreue		7			
2.3) Auftragsabwicklung		3,5			
2.4) Techn. Beratung / Betreuung		3,5			
			Erreichte Punktzahl		
			<input type="text" value="0"/>		
3.) Konditionen	0 ... 100		max 700		
3.1) Preisgestaltung		4,2			
3.2) Verträge / Lieferkonditionen		2,8			
			Erreichte Punktzahl		
			<input type="text" value="0"/>		
Gesamtpunktzahl:	möglich: <input type="text" value="7.000"/>	erzielt: <input type="text" value="0"/>	=	<input type="text" value="0"/>	
Einstufung:	<input type="text" value="A"/>				Lieferant

## 3.2 PPM - Management / Individual Quality Assurance Agreements

In order to operationally implement the strategic goal of "zero defect quality", the delivery quality at HJS is also recorded in PPM.

(ppm = parts per million / maximum number of failed parts per delivered million parts).

This parameter is included in the supplier evaluation. HJS and the supplier agree measurable targets for delivery quality (ppm target agreements), particularly in the case of increased risk, e.g. a poor supplier rating or a large number of repetitive complaints. The target value is defined in ppm.

$$\text{ppm} = \frac{\text{Value Not OK Parts}}{\text{Value Delivered Parts}} \times 10^6$$

The ppm results are recorded at HJS, communicated to the supplier and included in the supplier evaluation. At the same time, they form the basis for targeted measures to continuously improve quality. Exceeding the key figure is handled in the same way as in chapter "Escalation procedure for suppliers".

- The agreement of ppm values does not imply a quality level accepted by HJS. All parts recognized as defective will not be accepted as a matter of principle and will be at the supplier's expense.

# 4.0 Continuous Improvement



The supplier has introduced a structured process of continuous improvement for all products, processes, operational procedures and services in his company and verifiably applies it to the products delivered to HJS and all activities related to the business relationship.

This must contain:

## ➤ **4.1 Regularly requalification process**

All products must be subjected to a full dimensional and functional test at appropriate intervals / in accordance with the production control plans, taking into account the applicable customer specifications for material, function and packaging. The results must be available for customer reviews. This must be documented in the specific production control plans. A parts family formation / group formation is permitted here! If we have to pass on separate demands from our customers to you, these can be found in the EMPB order. If the test fails or production is suspended for 12 months, a new internal PPF process must be carried out.

## ➤ **4.2 Regularly process and product audits**

The supplier regularly carries out internal audits (e.g. VDA volume 6 parts 3 and 5) planned in advance for all products delivered to HJS and the processes associated with their development and manufacture. In the event of any deviations, the supplier immediately initiates all necessary corrective measures and ensures their effective implementation over the long term.

In addition, HJS is entitled to carry out a process, product or system audit at any time after prior notification to check whether the supplier's quality assurance measures meet HJS requirements. Should it be necessary, this can be done under the supervision of our customers.

If quality problems occur that are caused by services and/or deliveries by the supplier's subcontractors, the supplier must, at HJS' request, carry out an audit with the participation of HJS at the subcontractor side and disclose the results to HJS.

Details on the standards and methods of quality, sustainability and environmental management listed in the guideline can be found in the following literature in the latest edition. On request, HJS supplier management is willing to support you in the interpretation and introduction of methods and standard requirements.

Further Literature:

- IATF 16949 Quality management system standard of the automotive industry
- DIN EN ISO 9001 Qualitätsmanagementsystem
  
- VDA Band 1 Guide to the documentation and archiving of quality requirements and quality records
- VDA Band 2 Product and process release
- VDA Band 4 Quality assurance before series production
- VDA Band 6.3 Processaudit
- VDA Band 6.5 Productaudit

Internal Documents:

- S3-FB-08 Request for special release
- S3-FB-08 Customer Complaint Report / 8D – Report
- C2-AA-09 Description of feature types.
- C2-AA-72 Special features in the development process

Published on: <https://www.hjs.com/unternehmen/einkauf/>

***If you have any questions or comments, please do not hesitate to contact our supplier management team. We would also support you in implementing this guideline:***

M. Schein  
Qualitymanager Suppliermanagement  
Phone: +49 2373 987-352  
E-Mail: [markus.schein@hjs.com](mailto:markus.schein@hjs.com)

U. Antoni  
Suppliermanagement  
Phone: +49 2373 987-341  
E-Mail: [ute.antoni@hjs.com](mailto:ute.antoni@hjs.com)



HJS Emission Technology GmbH & Co. KG  
Dieselweg 12  
D-58706 Menden/Sauerland



Telefon +49 2373 987-0  
Telefax +49 2373 987-199



E-Mail: [hjs@hjs.com](mailto:hjs@hjs.com)  
Internet: [www.hjs.com](http://www.hjs.com)

